

► MAST STEP ON KEEL

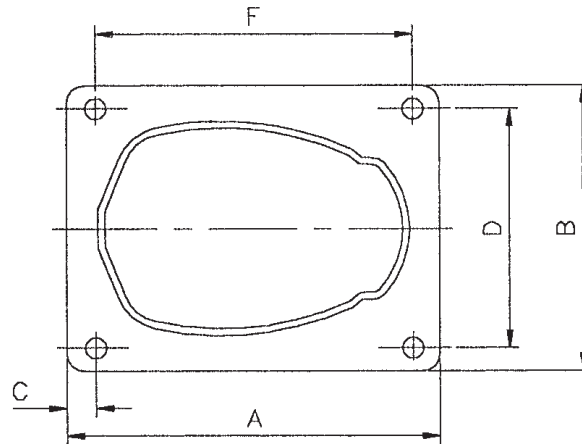

2004

PROFILE	REF	A mm	B mm	C mm	D mm	F mm	Thickness below profile
I180	36032401803	203	120	10	100	183	8 mm
I260	36032402603	214	130	15	100	180	8 mm
I330	36032403303	226	134	15	102	198	11 mm
NG51	36032400513	236	148	15	122	208	11 mm
NG86-105	36032400863	360	186	30	144	270	18 mm

► INTERNAL WATER-PROOFING

Extrusion	Reference
F35	35502000035
F50	35502000050
F67	35502000067
F101	35502000101
I180	35503000180
I260	35503000260
I330	35503000330
NG51	35505000051
NG60	35505000060
NG70	35505000070
NG80	35505000080
NG86	35505000086
NG105	35505000105

